

ENERGY EFFICIENT APPROACH IN WSN USING LEACH PROTOCOL

Vandana Rani¹, Sudesh Nandal²

¹M. Tech Student, ²Assistant Professor in ECE DEPARTMENT
BPSMV, Khanpur Kalan, Sonipat, Haryana, India

Abstract- A WSN (Wireless Sensor Network) consists of sensor nodes with restricted power supply along with constrained computational and transmission ability. It is essential to activate the sensor network for an extended period of time in an energy efficient way for getting-together sensed information. Due to the limited transmission as well as ability of performing computations and high compactness of sensor nodes, data packets forwarding takes place in multi-hop data broadcasting. The efficiency of sensor networks robustly depends on the routing protocol used. Routing protocols provide the most advantageous data communication path from sensor nodes to sink to save energy of nodes in the set of connections. This paper presents simulation results of presented clustering algorithms for hierarchical WSN. The simulation results show how the election criteria designed for cluster heads selection such as random selection and nodes with different energy level leaves an impact on the number of cluster heads selected and the set of connections (Network) duration. In this paper, we analyze LEACH protocol. Simulation results are provided to demonstrate the comparative efficiency of dissimilar clustering algorithm on network duration and cluster head selection along with failure nodes in the network.

Keywords- WSN, Energy Efficiency, Routing, LEACH.

1. INTRODUCTION

A WSN is a network consisting of many sensor nodes and base station (BS). All sensor nodes can be used to collect data and transmit sensing data to the base station (BS). In wireless sensor network, there are many types of nodes viz fixed node, Normal node, Intermediate node, Advance node. A fixed node is used in wireless communication and is deployed in the centre of the environment that can be used to collect data from the base station (BS) and the BS is called as other sensor node. Sometimes, transmitter and receiver are not in the area (neighbourhood) and that's why they use multihop distance with each other. This distance leads to consumption of more energy as compared to other techniques. In wireless sensor networks, the data transmission and reception between the nodes consume energy which is the amount of energy for each node to/from the other nodes. For a wireless sensor network, energy consumption is the summation of energy consumed by the various network nodes connected in the same network. In WSN, we use energy sources which are irreplaceable and used to show the network lifetime and various protocols are used to improve the energy of the networks [1]. Due to limited power for each node, we use routing algorithm for energy efficient. The routing algorithms are used to provide a route for data transmission and find path for less energy consumption for data transmission between various nodes. It is desirable to extend the network lifetime. The energy efficient routing algorithms are used to provide an energy efficient path/route for data transmission between various nodes via sensors and in this manner they drain their energy quickly. For this purpose, multi-hop and multi-path techniques are taken into consideration for transmission of data to base station (BS) according to ability of sensor nodes [2].

1.1 Wireless Sensor Network Model

A wireless sensor network model as shown in Fig.1.1 consists of sensor field, sink and task manager node. The number of nodes in WSN's is higher than that of ad-hoc networks.

- **Sensor Field-** A sensor field can be measured as the region in which the nodes are positioned.
- **Sensor Nodes-** Sensors nodes are the main part of the network. They are in charge of collecting data and routing this information back [3].
- **Sink-** A sink is a sensor node with the detailed task of reception, processing and store the data from other sensor nodes. They hand round to reduce the total number of letters that need to be sent, hence dropping the large energy desires of the network. Sinks are also known as data aggregation points [3].
- **Task Manager-** The task manager, also known as sink (base station) is a centralised point of organization within the network, which extracts in sequence from the network and disseminates organized information back into the network. It also serves as an entryway to other networks, a powerful data giving out and storage centre and an admission point for a human boundary. The base station can also be a laptop or a workspace [3].

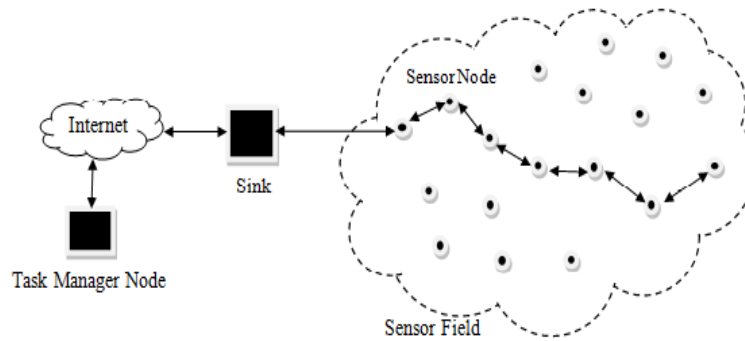

Fig.1.1 Configuration of WSN

Data is streamed to these workstations either via wireless channels, the internet, satellite etc. So, hundreds to several thousand nodes are deployed right the way through a sensor field to fashion a wireless multi-hop set-up. Nodes can use wireless letter medium such as infrared, radio, visual medium or Bluetooth for their communication. The communication sort of the node varies according to the statement procedure used [4].

1.2 CLASSIFICATION OF WIRELESS SENSOR NETWORKS

A Wireless Sensor network can be classified as shown in **Fig.1.2** based on their mode of execution and the type of target function.

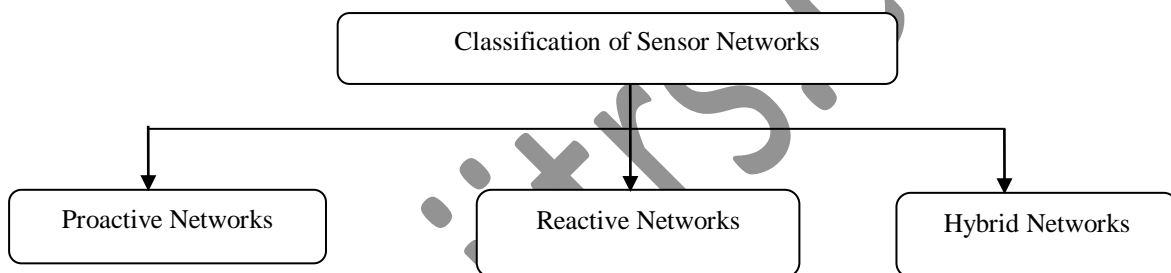

Fig.1.2 Classification of WSN

1.2.1 Proactive Networks

In proactive networks, nodes regularly switch ON their sensors and sender performs the task of sensing the situation and sends the data of interest. Thus, they provide a snapshot of the relevant parameters at regular intervals. These types of networks are well suited for applications requiring periodic monitoring of data. Some known instances of this kind are the LEACH protocol and some improvement of LEACH protocol [6].

1.2.2 Reactive Networks

In such type of networks, the nodes react immediately to sudden and drastic changes in the value of a sensed attribute. These types of networks are well suited for time critical applications. Recent advances in wireless sensor networks have given birth to many new protocols particularly designed for sensor networks where energy awareness is an essential consideration. But methods like Direct Communication and Minimum Transmission Energy do not promise unbiased energy allocation among the sensing nodes. In Direct Communication Protocol, each sensor node sends information straight to the BS, despite the concerns of distance [7].

Due to this, the nodes farthest from the BS are the ones to die first. On the other hand, in case of Minimum Transmission Energy routing protocol, data reaches the base station through intermediate nodes. Thus each node senses the environment and starts acting as a router to the data of other nodes at the same time. Nodes closest to the sink (BS) are the first to die in MTE routing. So far, cluster-based method is among one of the approaches which has gained success in increasing the lifetime and stability of the entire sensor networks [8].

1.2.3 Hybrid Networks

The nodes in these type of networks not only react to critical-time conditions, but also give a general picture of the network at cyclic intervals in a very energy proficient way. With the help of these networks, users can request present, past, and future data from the network [9].

1.3 ROUTING PROTOCOLS

Protocol is a set of rules to guide a network how to transfer a data within the same network or different network. Protocols for Sensor networks must be designed in such a way that results in the efficient use of limited power existing at the sensor nodes. Routing in WSN is quite challenging due to its inherent limitations and basic features that differentiate WSN from other wireless networks. LEACH protocol is used for energy efficiency management in WSNs [10].

1.3.1 LEACH

It is abbreviated as Low Energy Adaptive Clustering Hierarchy Protocol. It was discovered in 2000. It considers designing of an effective radio and energy model [11]. Proactive Network is used in LEACH. LEACH is the first and most popular hierarchical clustering algorithm for energy-efficiency management in WSNs that was suggested for dropping power intake [11]. Its Goal is to minimize energy consumption in wireless sensor network. In LEACH, the clustering as shown in **Fig.1.3**, task is rotated among the nodes, based on interval. Each cluster head (CH) performs straight communication to forward the data to the sink. It uses clusters approach to increase the life of the Wireless Sensor Network (WSN). LEACH is based on an aggregation (or fusion) technique that does the task of aggregation of the original data into a lesser size of data that carry only significant information to all individual sensors [12].

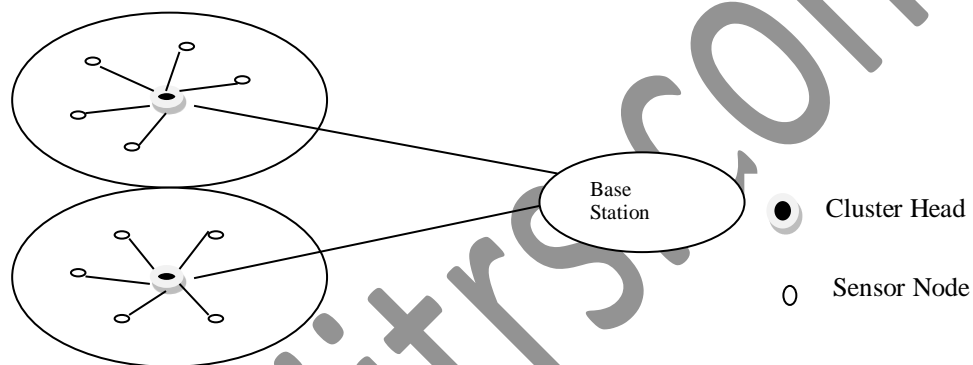

Fig.1.3 Clustering in LEACH Protocol [12]

LEACH protocol partitions the network into numerous clusters of sensors, which are constructed by using localized synchronization and control not only to lessen the extent of data that are transmitted to the sink, but also to make routing and distribution of data more scalable and vigorous. Instead of selecting in stationary manner, LEACH uses a randomize rotation for cluster head selection, to provide a chance to all sensors to act as CHs and avoid the battery exhaustion of an individual sensor and dying rapidly [12].

The procedure of LEACH is divided into rounds each of which has two phases as shown in **Fig.1.4**.

- A setup phase for the association of the network into clusters, CH advertisement, and creation of transmission schedule [13].
- A steady-state phase which consists of phases like aggregation of data, compression of data and transmission to the sink [13].

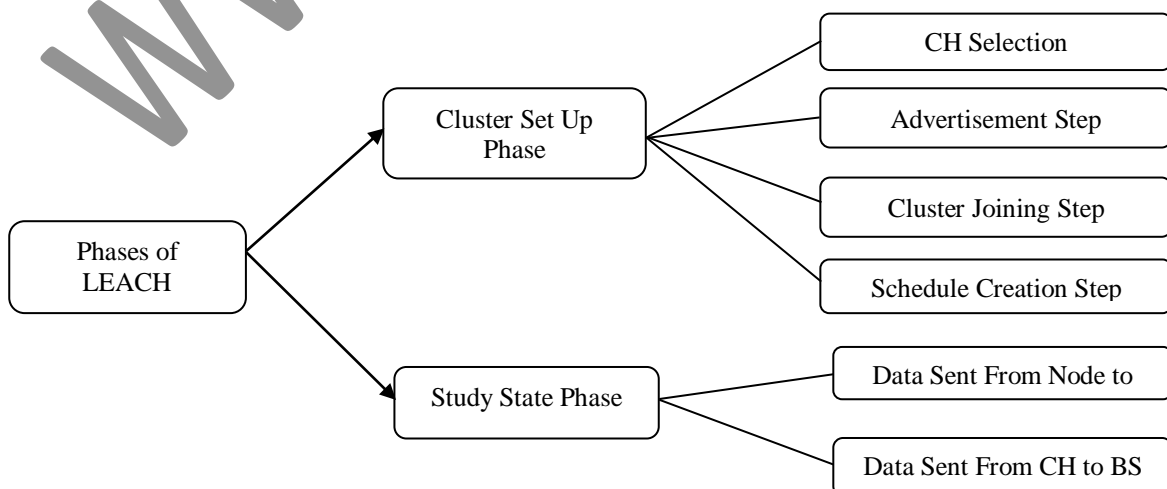

Fig.1.4 Phases of LEACH

LEACH is completely distributed and therefore, it does not require overall knowledge of the network. It decreases energy consumption by (a) minimizing the announcement cost between sensors and their Cluster Head's (CHs) and (b) turning off non-head nodes as much as feasible. Low energy adaptive clustering hierarchy protocol (LEACH) uses single-hop routing where each node is capable of transmitting directly to the cluster-head and the base station (sink). Therefore, it is not applicable to networks deployed in large provinces. Moreover, the idea of dynamic clustering brings extra overhead, e.g. head changes, advertisements etc., which may lessen the gain in energy consumption. While LEACH helps the sensors within their cluster dispel their energy gradually, the cluster heads consume a larger amount of energy when they are located farther away from the sink. Also, the termination of LEACH clustering takes place in a finite number of iterations, but does not guarantee good distribution of cluster heads and assumes even energy depletion for CHs [14].

1.3.2 Strengths of LEACH

- Cluster head selection is done at regular intervals
- Cluster head rotated randomized manner

1.3.3 Limitations of LEACH

- It doesn't give guarantee if good CH is distributed
- Cost of the formation CH is expensive
- Random selection of CH in the vicinities
- They have low node density

1.4 APPLICATIONS OF WSN

Wireless Sensor networks (WSN) enclose a broad variety of applications and systems by way of enormously altering needs along with description. The wireless sensor networks (WSN) can be used as shown in **Fig.1.5**.

- Medical and health care.
- Military environment.
- Disaster management.
- Industrial fields, home.
- Habitat monitoring.
- Networks, Biological, detecting chemical, nuclear, radiological, and explosive material etc.

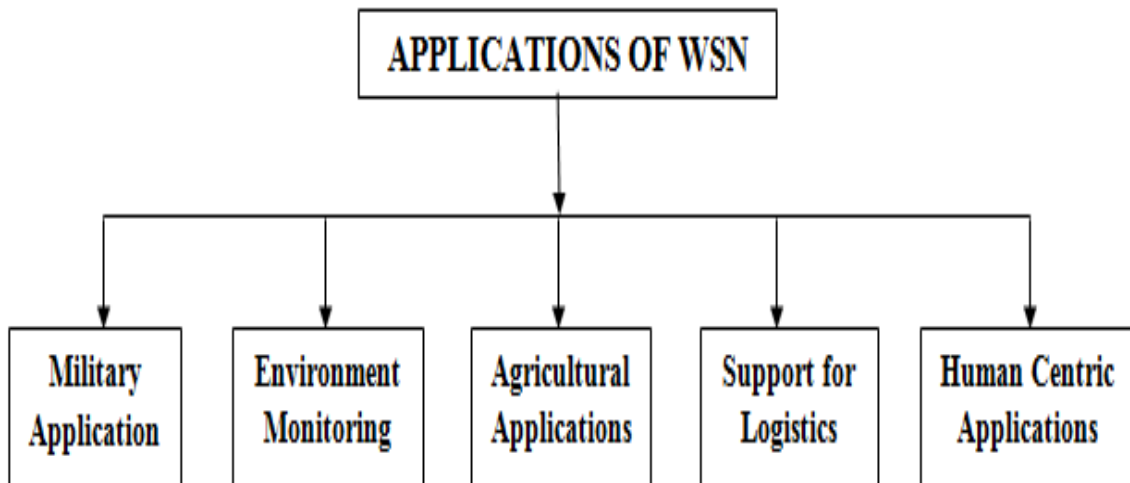

Fig.1.5 Applications of WSN

2. IMPLEMENTATION & RESULTS

There are several simulators available like MATLAB, QualNet, OMNET++, NS2, OPNET and lab view to check the performance of protocols. In present study, MATLAB is used with the integrated radio model of LEACH protocol.

2.1 Architecture Algorithm

The methodology adopted in the modeling and simulation is presented in the architecture diagram as shown in Fig.2.1 with slight modifications as described below- To evaluate the performance of leach protocol, we have implemented it on the MATLAB with the incorporated model of advance leach protocol.

International Journal of Technical Research & Science

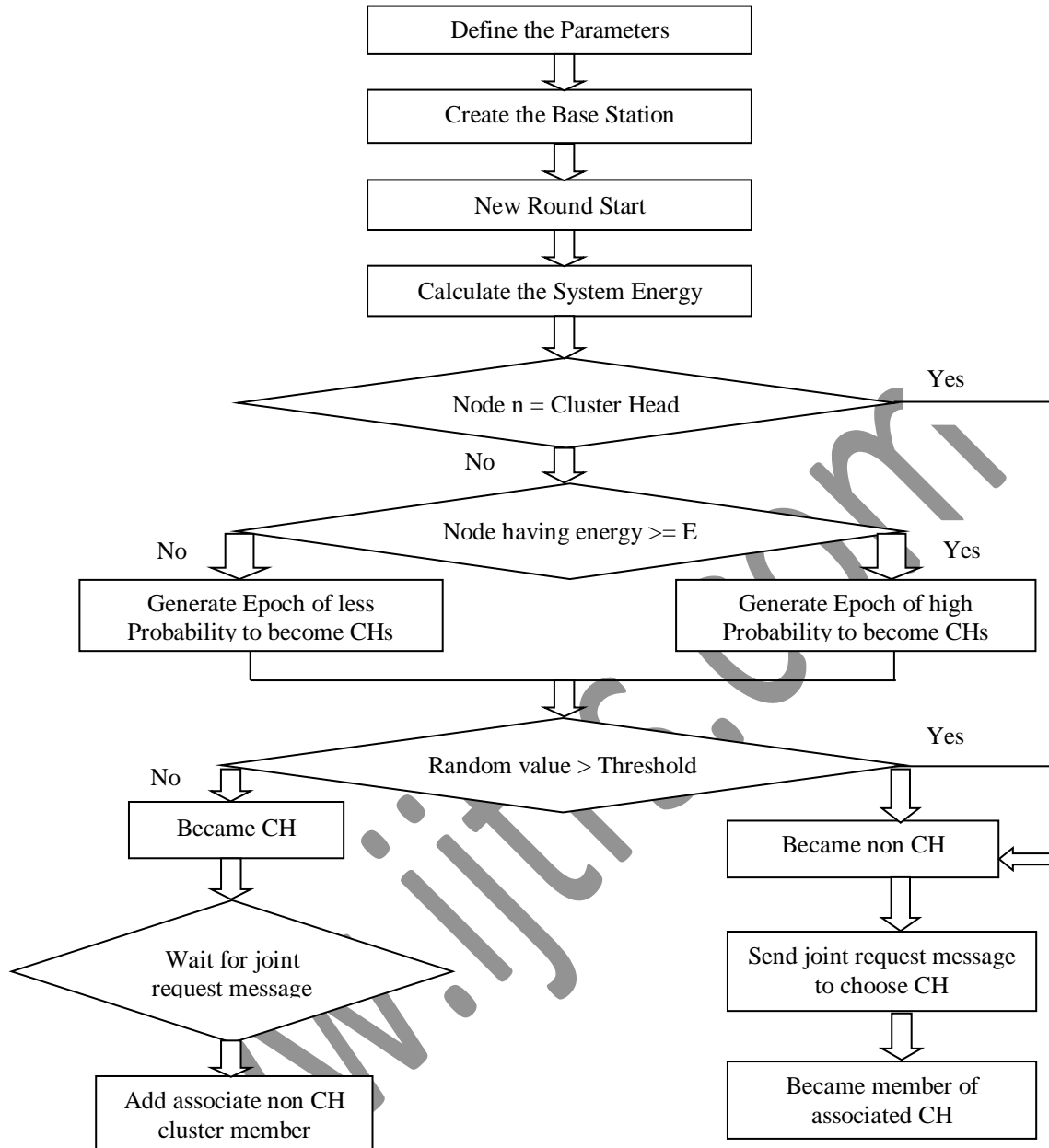

Fig.2.1 Process Flow

2.2 Energy Calculation in Leach Protocol

For calculation of energy in LEACH Protocol, we will consider first order *radio model* [15]. For this, some assumptions have to be made:

We suppose a straight forward representation everywhere the transmitter dissipates energy to sprint the two-way radio electronics and the control amplifier, and the receiver dissipates energy to run the two-way radio electronics, as shown in Fig. 2.2. It is concluded that following steps needs to be taken in order to minimise the energy dissipation.

- By arranging the state of nodes
- By varying the transmission range between various sensing nodes
- By using efficient routing and data collection methods

All routing protocol uses this radio model for transceive the data. This model assumes two models for transmit amplifier.

2.2.2 Free Space Model

During transmission of data if the distance between sender and receiver is less than specific distance (threshold distance (d_0)), transmitter amplifier assumes this model.

2.2.3 Multipath Fading Signal Model

In case of a greater distance between sender and receiver than specific distance (threshold distance (d_0)), transmitter amplifier assumes this model.

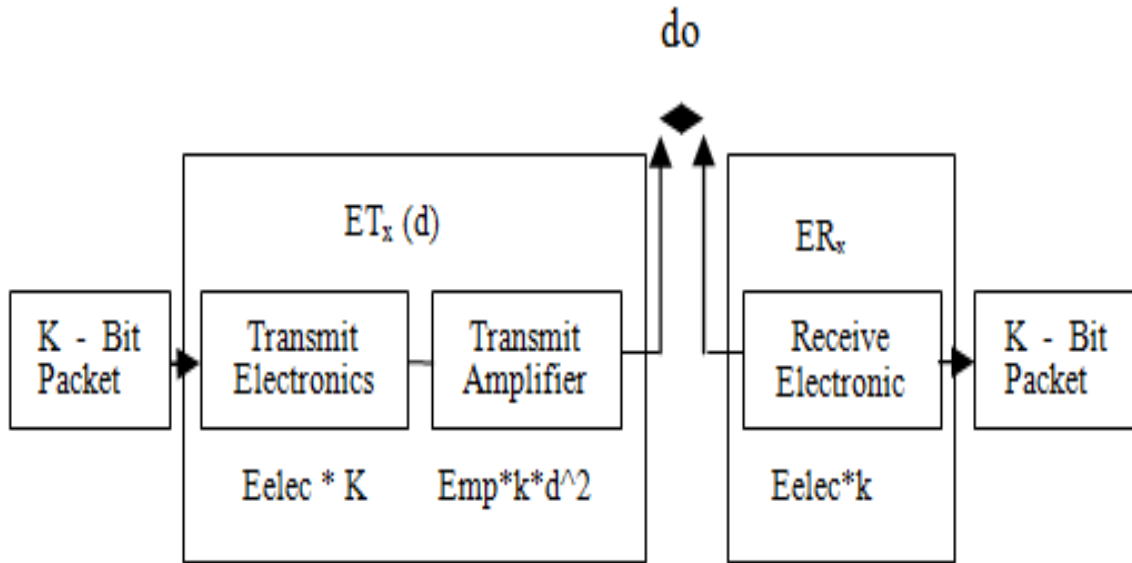

Fig. 2.2 First Order Radio Model

This paper presents an improved Leach Protocol for cluster head selection algorithm. The cluster formation is not the topic of this paper. We use radio model for energy efficiency in WSNs. Energy consumption calculation can be done as follows:

ETx (Etrans)	:	Energy loss on Transmission
ERx (Erec)	:	Energy loss on Receiving
Efs (E_loss_Forwd)	:	Energy Loss on Forward
Emp (E_loss_Rx)	:	Energy Loss on Cluster Switch
EDA (E_loss_Delay)	:	Energy Loss on Delay
Rmax (Round)	:	Number of rounds
M	:	Number of advanced nodes

The following equations characterize the sum of energy utilization in transmitting envelopes through k bits in excess of d_0 distance.

$$ETx = k * Eelec + k * Efs * d^2 \quad \text{If } d \leq d_0 \quad 2.1$$

$$ETx = k * Eelec + k * Efs * d^4 \quad \text{If } d > d_0 \quad 2.2$$

$$d_0 = \sqrt{Efs/Emp} \quad 2.3$$

By observing formula given in equation (2.3), energy dissipation can be minimized. So that network lifetime of wireless sensor network can increase.

2.2.4 Problem Formulation

In LEACH protocol cluster head is selected for each node n determines a random number between 0 and 1. For a node to become a cluster head for the current round, the number should be less than a threshold $T(n)$. The threshold is set as follows:

$$T(n) = \begin{cases} \frac{P}{1 - (P * (r \bmod 1/p))} & , \text{ if } n \in G \\ 0 & , \text{ Otherwise} \end{cases}$$

P is probability of cluster head, G is the set of nodes that have been cluster heads in the last $1/p$ rounds and r is the number of current rounds. This algorithm ensures that every node becomes a cluster head exactly once within $1/p$ rounds.

Initializations of Parameters- There are some experimental parameters are shown in Table 2.1.

Table-2.1 Routing Simulation Parameters

PARAMETERS	VALUE
Area	100*100 Square Meters
Initial Energy	0.1 Joule
No of Nodes (N)	100
E_loss_Rx (Emp)	0.0013*0.000000000001
E_loss_Forwd (Efs)	10*0.000000000001
do	87.705801930702930
Round (Rmax)	100
Etrans (ETX)	50*0.000000001
Erec (ERX)	50*0.000000001
E_loss_Delay (EDA)	5*0.000000001
Prob (Probability)	0.2

Energy is most significant parameter in cluster formation. **Fig.2.3** shows the initial nodes distribution in LEACH method. In leach protocol, there are two types of nodes: advance nodes (plus sign) and normal nodes (circle sign). **Fig.2.4** shows sensors that are alive (dotted circles) and dead sensors (dots) after 100 rounds (of data transmission) in LEACH algorithm. **Fig.2.5** shows the position of sensor nodes and formation of cluster head is shown in. **Fig.2.6** describes the average energy of each node in the specified round number after the transmission has taken place through LEACH algorithm. The performance of LEACH in the network system is presented in **Fig.2.6**. The increase in the network size, results in increasing the number of hops for transmission of data.

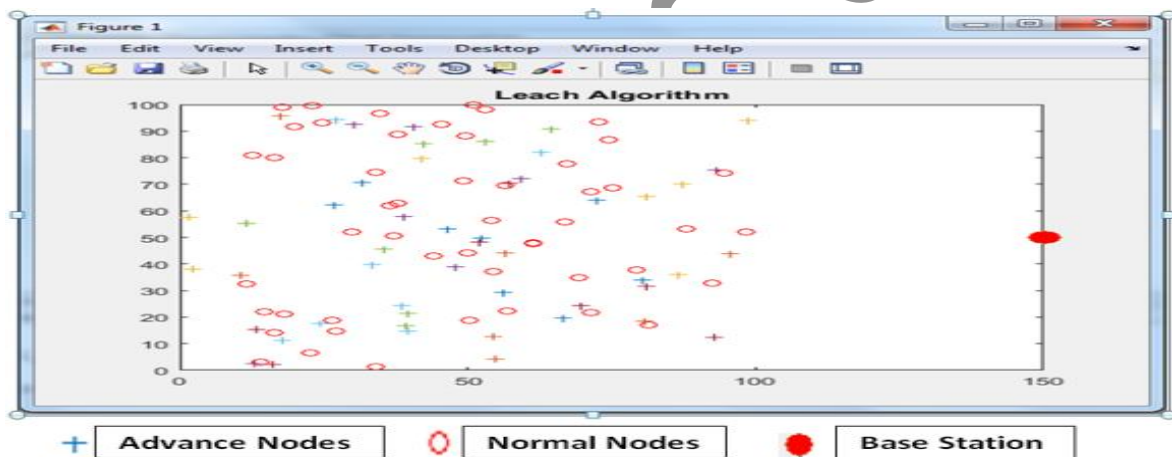

Fig.2.3 Deployment of Sensor Nodes

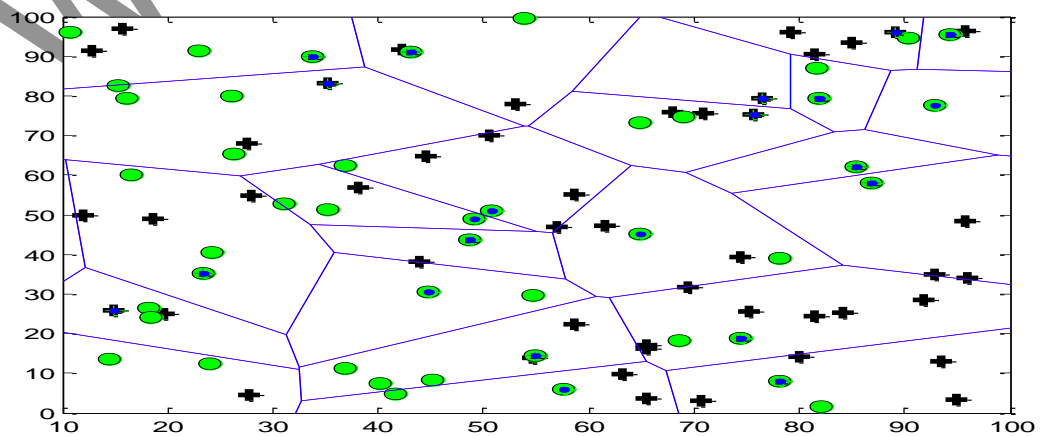

Fig.2.4 Node Cluster

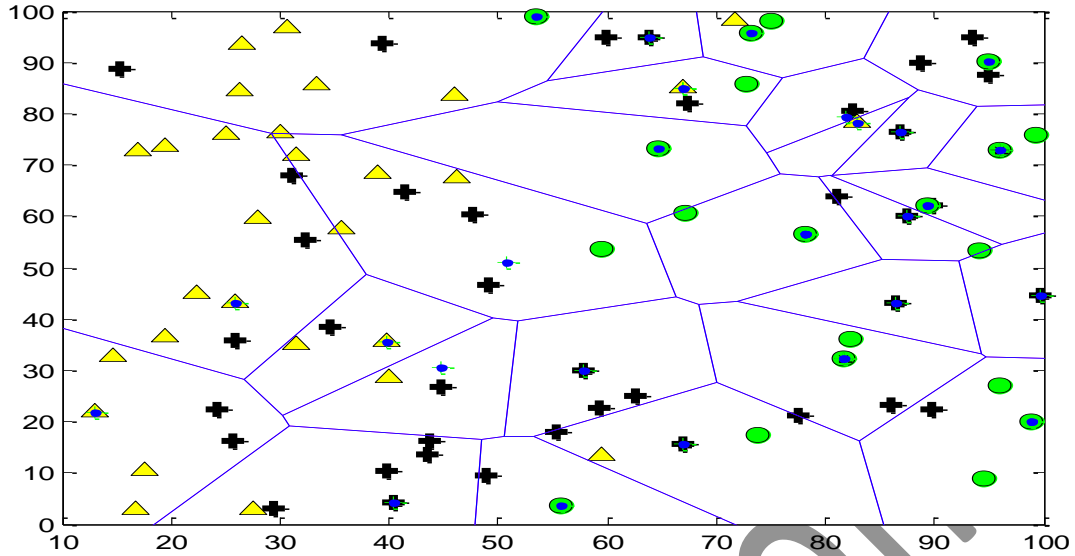

Fig. 2.5 Node Energy Shifting in Cluster

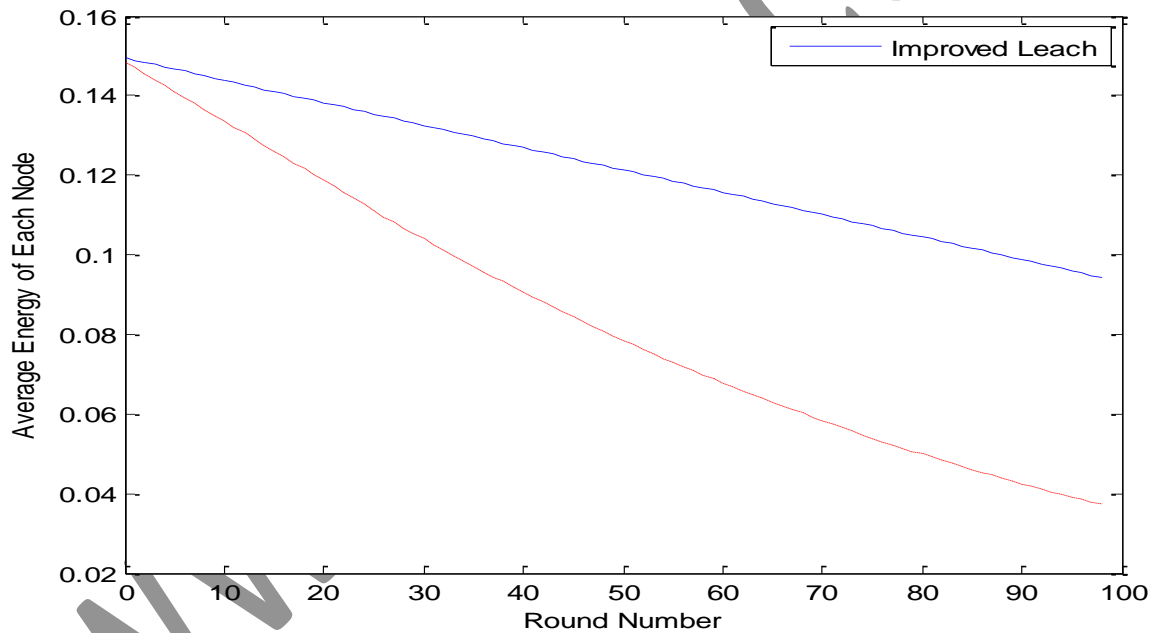

Fig. 2.6 Round Number Vs Average Energy of Each Node

CONCLUSION

In this paper, LEACH was analyzed for energy proficient clustering algorithms for heterogeneous (WSN) wireless sensor network. The simulation outcome show how the selection criteria for cluster heads election such as Initial energy E_0 , probability with existence of advance nodes with dissimilar energy level as well as base station area have an effect on the number of cluster heads selected and the network duration. Simulation results are provided to show the relative efficiency of different clustering algorithm on network duration, cluster heads choice. We have evaluated the performance of LEACH using MATLAB.

REFERENCES

- [1] Ehsan Amiri, Hassan Keshavarz, Mojtaba Alizadeh, Mazdak Zamani, and Touraj Khodadadi , “Energy Efficient Routing in Wireless Sensor Networks Based on Fuzzy Ant Colony Optimization”, Department of Computer Engineering, Nourabad Mamasani Branch, Islamic Azad University, Nourabad, Mamasani, Iran.

- [2] Haifeng Jiang, Yanjing Sun, Renke Sun, and Hongli Xu, "Fuzzy-Logic-Based Energy Optimized Routing for Wireless Sensor Networks", School of Computer Science & Technology, China University of Mining and Technology, China.
- [3] Karp and H. T. Kung, "GPSR: greedy perimeter stateless routing for wireless networks", in Mobile Computing and Networking, pp. 243–254, 2000.
- [4] Gaurav Sharma, "Routing In Wireless Sensor Networks", Computer Science and Engineering Department, Thapar University Patiala, 2009.
- [5] Anuj Kumar, "Wise MAC Protocol for Wireless Sensor Network-An Energy-Efficient Protocol", Department of Electronics & Communication Engineering, National Institute of Technology Rourkela, 2014.
- [6] M.J. Handy, "Low Energy Adaptive Clustering Hierarchy with Deterministic Cluster-Head Selection", Institute of Applied Microelectronics and Computer Science University of Rostock, Germany.
- [7] Zhan Wei Siew, "Fuzzy Logic Based Energy Efficient Protocol In Wireless Sensor Networks", Modelling, Simulation & Computing Laboratory, Material & Mineral Research Unit, School of Engineering and Information Technology, Malaysia, ICTACT Journal On Communication Technology, Volume 03, Issue 04, pp. 639-645, December 2012.
- [8] Arati Manjeshwar and Dharma P. Agrawal, "TEEN: A Routing Protocol for Enhanced Efficiency in Wireless Sensor Networks"
- [9] Li Qing, Qingxin Zhu, Mingwen Wang, "distributed energy-efficient clustering algorithm for heterogeneous wireless sensor networks", School of Computer Science and Engineering, University of Electronic Science and Technology of China.
- [10] Mohini Kumrawat, Manoj Dhawan, "Survey on Energy Efficient Approach for Wireless Multimedia Sensor Network", (IJCSIT) International Journal of Computer Science and Information Technologies, Vol. 5(4), 2014, pp 5517-5520.
- [11] Rajeshwar Dass, "Wireless Communication System", LK International Pvt. Ltd.
- [12] Parvathi C, Dr. Suresha, "Existing Routing Protocols for Wireless Sensor Network – A study", International Journal of Computational Engineering Research (IJCER), Vol. 04, Issue 7, July – 2014.
- [13] Honey A. Soni, "Energy Efficient Routing Protocols for Wireless Sensor Networks: A Survey", Advances in Computer Science and Information Technology (ACSIT), pp. 7-12, Volume 2, Number 7, April – June, 2015
- [14] Neha Sanadhya, "An Improved LEACH Protocol using Fuzzy Logic in Wireless Sensor Network", International Journal of Scientific Engineering and Research (IJSER), pp. 93-96, Volume 3 Issue 5, May 2015.
- [15] Sangita Vishwakarma, "An analysis of LEACH Protocol in Wireless Sensor Network: A Survey", International Journal of Computer Science & Engineering Technology (IJCSET), pp. 148-154, Vol. 6 No. 03, March 2015.